

AAAE NextGen

The NextGen Airport Enabled by Personal Rapid Transit

Peter Muller, P.E.
PRT Consulting
August 6, 2008





Improving Transportation Through
Innovative Engineering



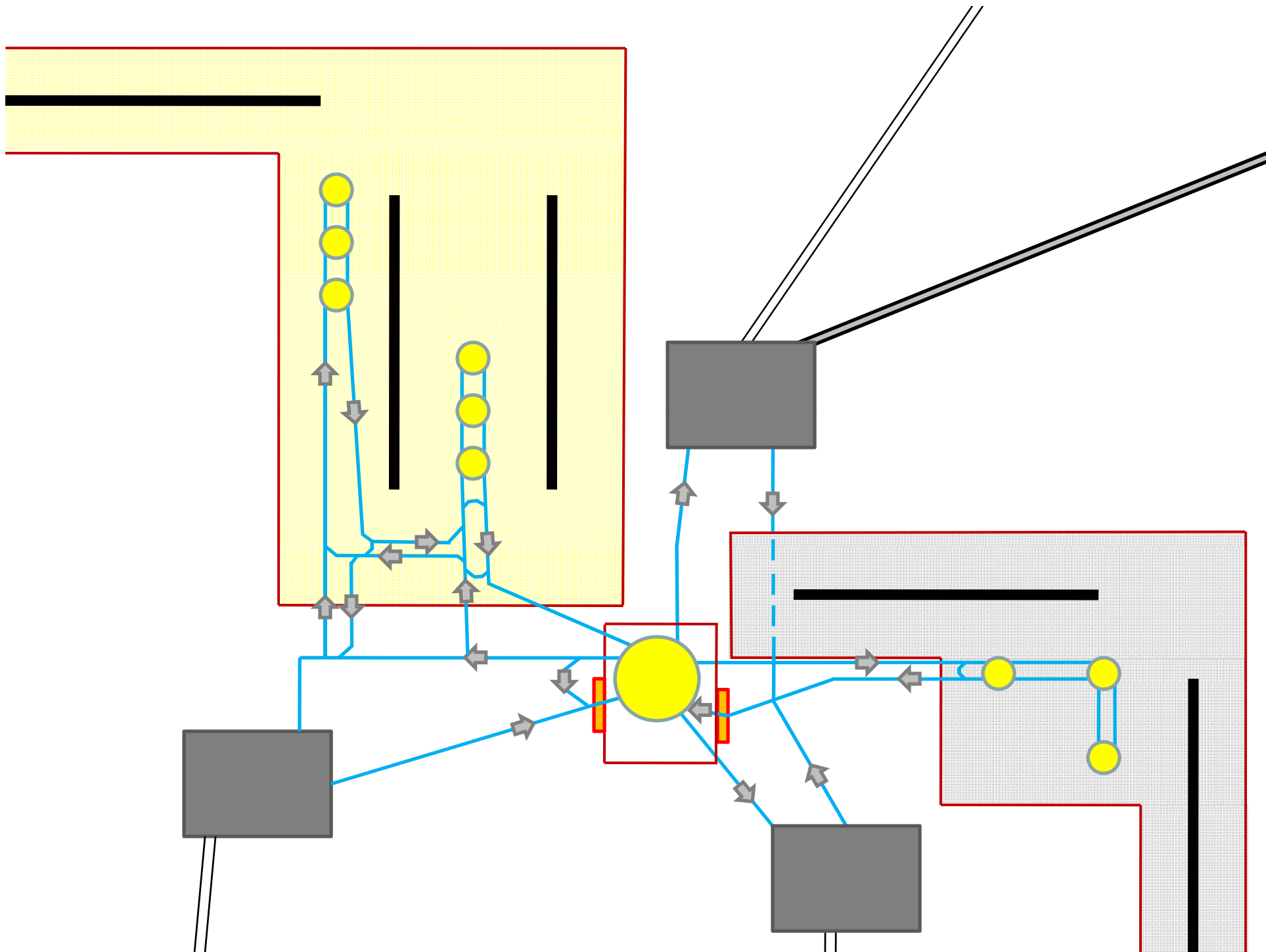

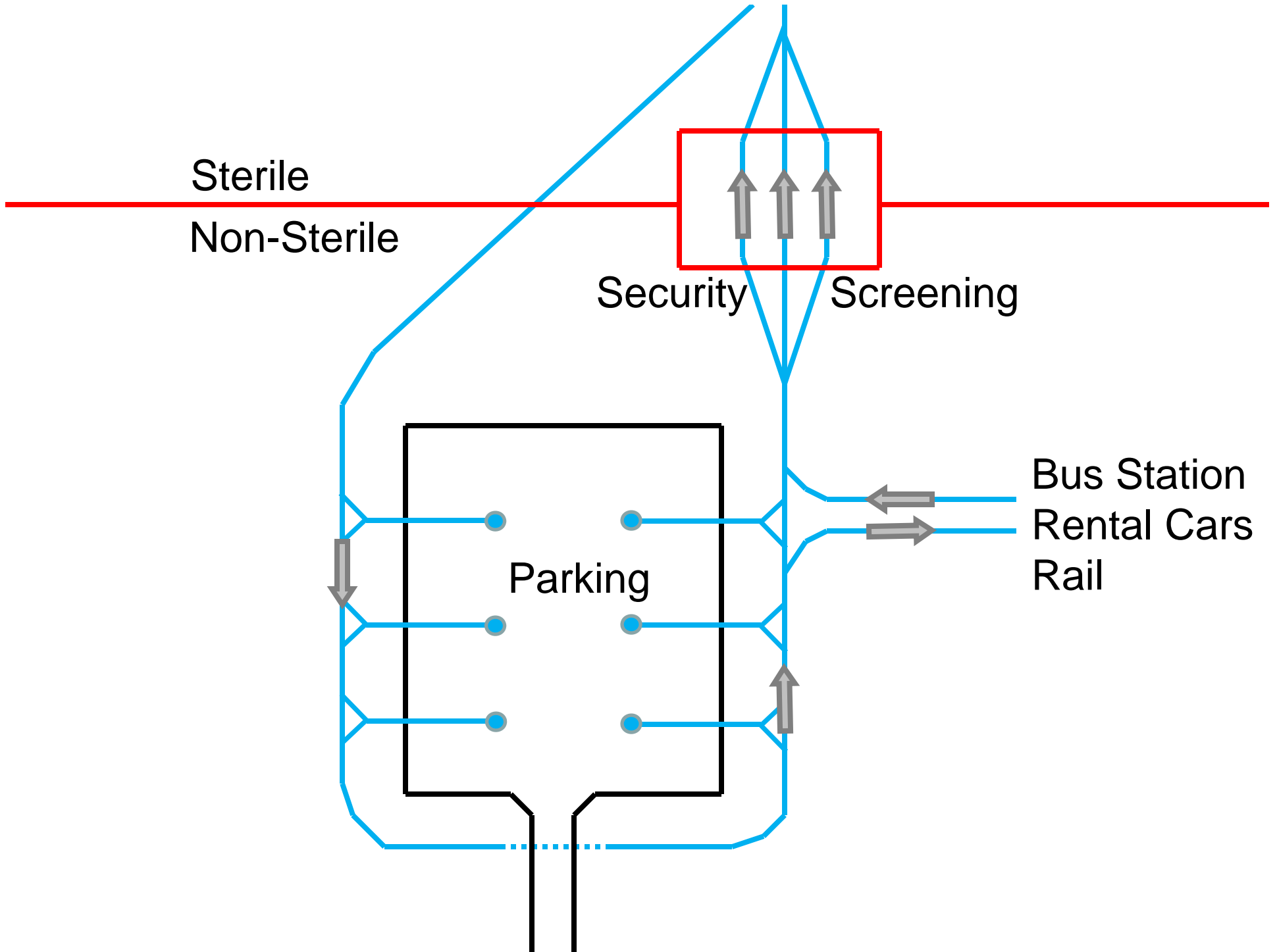

PRT-Enabled Screening

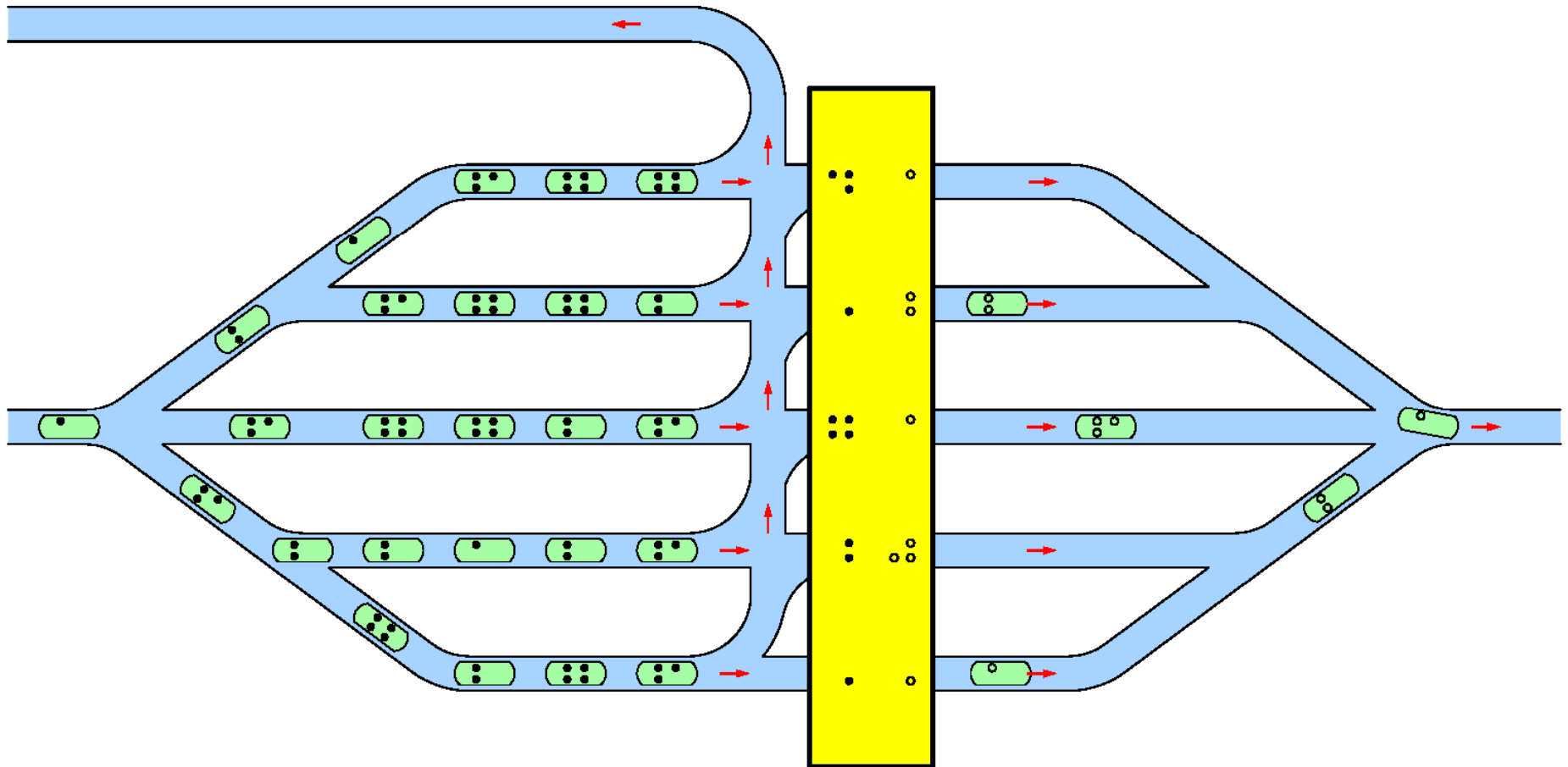

Remote Concourse

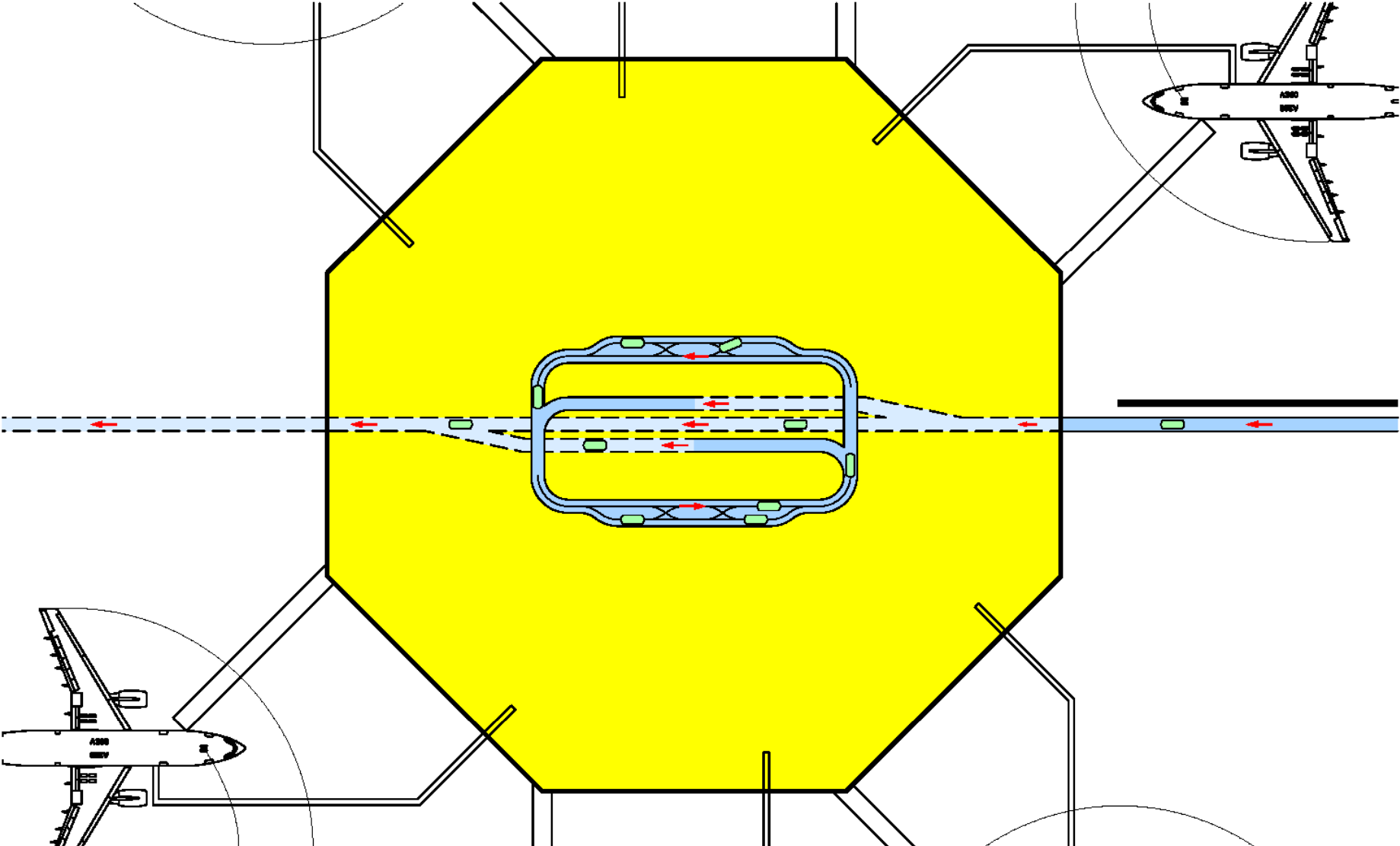

Past/GA

Present

Future

Car

MC

Walk

MC

W

Board

Car/Transit

Walk

Shuttle Bus

MC

W

Walk

Ticketing

W

Walk

Concessions

W

Walk

Escalator

MC

Walk

Security

W

Walk

Escalator

MC

Walk

People Mv

MC

Walk

Escalator

MC

Walk

Concessions

W

Walk

Board

MC

Car/Transit

MC

Walk

MC

PRT Ticketing

MC

Security

W

PRT

MC

Walk

MC

Concessions

W

Walk

MC

PRT

MC

Walk

MC

Board

MC

Mode
Process
Onerous /standing
Seamless /seated

2

1

14 6

8

2

General Benefits

- Lower construction costs/times/impacts
- Improved security
- Improved sustainability
- Consolidating waiting and concessions should improve revenues
- Streamlined process should cost less to operate
- Incremental implementation should be possible

A horizontal collage of four circular images: a bridge at sunset, two men in suits talking, a train, and a yellow excavator.

Improved Level of Service

- Less waiting
- Less mode changing
- Less uncertainty
- Seated travel
- More useable wait time
- Easier way finding
- Less crowding

First Class Airport Experience



Improving Transportation Through
Innovative Engineering



Contact Information

Peter Muller
PRT Consulting, Inc.
1340 Deerpath Trail, Ste 200
Franktown, CO 80116
Ph: 303-532-1855
Cell: 720-318-4795
Fax: (303) 309-1913
www.prtconsulting.com

